

PRODUCT INFORMATION PACKET



Model No: 364THFS19047BN

Catalog No: 811567.00

60HP..1770RPM.364.TEFC./V.3PH.60HZ.CONT.NOT.40C.1.15SF.RIGID.IEEE-841.364THFS19047AN
IEEE 841



Regal and Leeson are trademarks of Regal Beloit Corporation or one of its affiliated companies.

©2018 Regal Beloit Corporation, All Rights Reserved. MC017097E





Nameplate Specifications

Output HP	60 Hp	Output KW	45.0 kW
Frequency	60 Hz	Voltage	460 V
Current	70.0 A	Speed	1780 rpm
Service Factor	1.15	Phase	3
Efficiency	95 %	Duty	Continuous
Insulation Class	F	Design Code	B
KVA Code	G	Frame	364T
Enclosure	Totally Enclosed Fan Cooled	Overload Protector	No
Ambient Temperature	40 °C	Drive End Bearing Size	6314
Opp Drive End Bearing Size	6312	UL	Recognized
CSA	Y	CE	Y
IP Code	56		

Technical Specifications

Electrical Type	Squirrel Cage Inverter Rated	Starting Method	Line Or Inverter
Poles	4	Rotation	Reversible
Mounting	Rigid base	Motor Orientation	HORIZONTAL
Drive End Bearing	BALL	Opp Drive End Bearing	BALL
Frame Material	Cast Iron	Shaft Type	T
Overall Length	13.25 in	Frame Length	13.50 in
Shaft Diameter	2.375 in	Shaft Extension	5.88 in
Assembly/Box Mounting	F1/F2 CAPABLE		
Outline Drawing	B-SS508590LE-1350	Connection Diagram	A-EE7300-LE

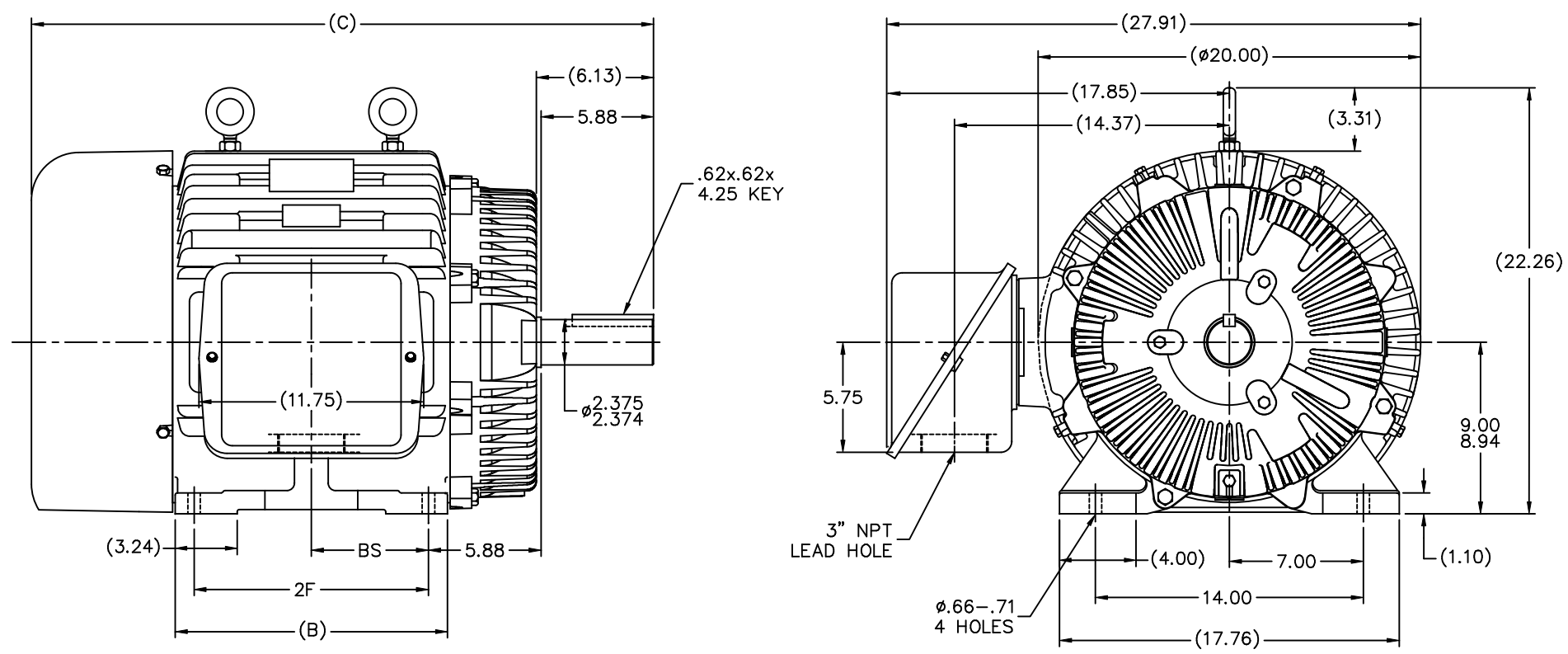

.62x.62x
4.25 KEY

3" NPT
LEAD HOLE

ø.66-.71
4 HOLES

- NOTES:
 1. CONDUIT BOX CAN BE ROTATED IN 90° STEPS.
 2. CONDUIT BOX CAN BE MOUNTED ON OPPOSITE SIDE BY REMOVING BRACKETS AND TURNING FRAME 180°.
 3. NAMEPLATES TO BE READ FROM CONDUIT BOX SIDE OF MOTOR.

(B-SS504688)

						TOLERANCES UNLESS SPECIFIED		ELECTRIC MOTORS GEARMOTORS AND DRIVES		DRAWN KL 02-16-2004												
						DEC.	INCHES			CHK	ML 02-16-2004											
						.X	±.1	TITLE OUTLINE - TEFC		APPD JES 02-16-2004												
						.XX	±.03	360T FR. - TAPPED LEAD HOLE		SCALE 3=16												
						.XXX	±.005	FINISH		REF												
						.XXXX	±.0005	MATL		FMF MU80127												
DASH	FRAME	B	C	2F	BS	NO.	REVISION	BY & DATE	CHK	ANG	±7'30"	PREV										
1350	364T	13.25	31.50	11.25	5.62	THIS DRAWING IN DESIGN AND DETAIL IS OUR PROPERTY AND MUST NOT BE USED EXCEPT IN CONNECTION WITH OUR WORK ALL RIGHTS OF DESIGN AND INVENTION ARE RESERVED THIS IS AN ELECTRONICALLY GENERATED DOCUMENT - DO NOT SCALE THIS PRINT						RFP	02-16-2004	CAD FILE	SS508590LE	SIZE	B	DRAWING NO.	SS508590LE	PAGE	OF	REV.
1450	365T	14.25	32.50	12.25	6.12							DIST	WA									

THREE PHASE - SINGLE VOLTAGE
MOTOR - CONDUIT BOX @ 'A'

TO REVERSE ROTATION:
INTERCHANGE ANY TWO LINE
LEAD CONNECTIONS

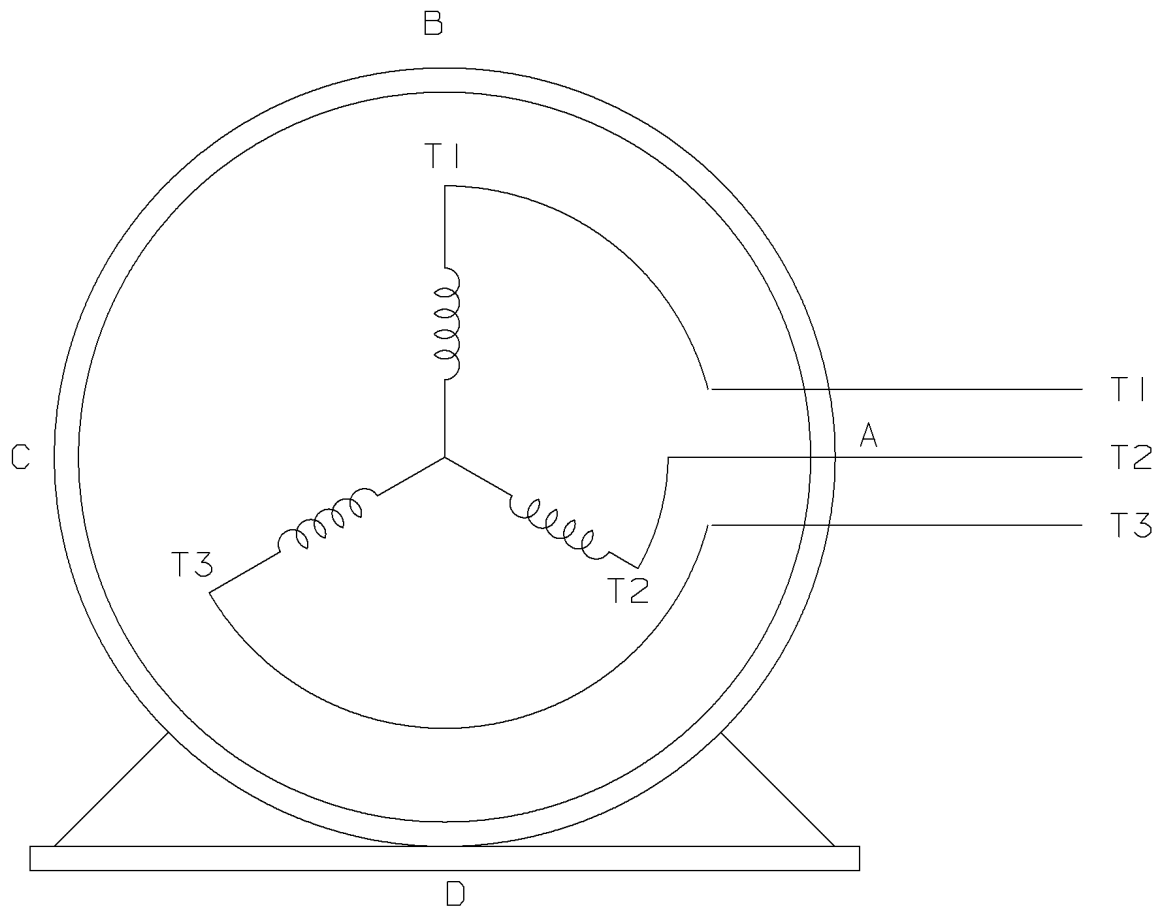

VIEW OF TERMINAL END

IF MOTOR HAS
6 LEADS

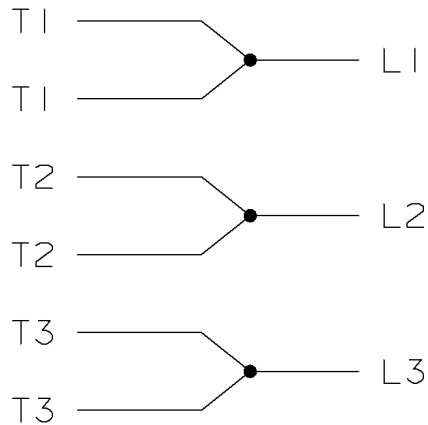

A-9806 DECAL

				TOLERANCES UNLESS SPECIFIED		 ELECTRIC MOTORS GEARMOTORS AND DRIVES	DRAWN MSG 05-22-2002			
				DEC.	TOLERANCE		CHK ML 05-22-2002			
				.X	± .1		APPD GK 05-22-2002			
				.XX	± .02		SCALE			
				.XXX	± .005		REF			
1	NEW DRAWING	MSG	05-22-2002	ML	.XXXX ± .0005	TITLE CONNECTION DIAGRAM SINGLE VOLT - 3Ø MOTOR	FMF			
NO.	REVISION	BY	DATE	CHK	ANG ± 7'30"	<input checked="" type="checkbox"/> SURFACE ROUGHNESS UNLESS SPECIFIED	MAT'L. FINISH	PREV		
THIS DRAWING IN DESIGN AND DETAIL IS OUR PROPERTY AND MUST NOT BE USED EXCEPT IN CONNECTION WITH OUR WORK. ALL RIGHTS OF DESIGN AND INVENTION ARE RESERVED. THIS IS AN ELECTRONICALLY GENERATED DOCUMENT - DO NOT SCALE THIS PRINT				PURCHASED		CAD FILE EE7300-LE	SHOP BOOK	SIZE	DRAWING NO.	REV.
				DIST WA - LB - WP - LM - BR - BR				A	EE7300-LE	I



P.O. BOX 8003
WAUSAU, WI 54401-8003
PH. 715-675-3311

DATA VOLTS: 460

CERTIFICATION DATA SHEET

CONN. DIAGRAM: A-EET7300-LE
OUTLINE: B-SS508590LE-1350
WINDING: T3654207

NONE 3

CAT #: 811567.00

TYPICAL MOTOR PERFORMANCE DATA

HP	KW	SYNC RPM	FL RPM	FRAME	ENCLOSURE	TYPE	KVA CODE	DESIGN	
60	45	1800	1780	364T	TEFC	TFS	G	B	
PH	HZ	VOLTS	AMPS	START TYPE	DUTY	INSL	S.F.	AMB	ELEV.
3	60	460	70	LINE OR INVERTER	CONT	F	1.15	40	3300
F.L. EFF	95.0	3/4 LD EFF	95.0	1/2 LD EFF	95.0	GTD EFF	ELECT. TYPE		
F.L. PF	85.0	3/4 LD PF	81.5	1/2 LD PF	73.5	94.5	SQ CAGE INVERTED		
F.L. TORQUE	LR AMPS @ 460 V	L.R. TORQUE	B.D. TORQUE	F.L. RISE (°C)					
177 LB-FT	435	335 LB-FT	189%	465 LB-FT	263%	80			
PRESSURE @ 3	POWER	ROTOR WK²	MAX. LOAD WK²	SAFE STALL TIME	STARTS/HOUR	MOTOR WGT			
65 DBA	74 DBA	15.2 LB-FT²	420 LB-FT²	25 SEC.	2	900 LB.			

*** SUPPLEMENTAL INFORMATION ***

DE BRACKET TYPE	ODE BRACKET TYPE	MOUNT TYPE	MOTOR ORIENTATION	SEVERE DUTY	HAZARDOUS LOCATION	DRIIP COVER	SCREENS	PAINT
STANDARD	STANDARD	RIGID	HORIZONTAL	UM SEVERE	DIVISION 2 T2B	NO	NONE	N - LEESON WATTS
BEARINGS	GREASE	SHAFT TYPE	SPECIAL DE	SPECIAL ODE	SHAFT	MATERIAL	FRAME MATERIAL	
DE BALL 6314	BALL POLYREX EM 6312	T	NONE	NONE	1045 HOT ROLLED (C-204)	CAST IRON		
THERMOSTATS	PROTECTORS	WDG RTD's	BRG RTD's	THERMISTORS	CONTROL	SPACE HEATERS		
NONE	NOT	NONE	NONE	NONE	FALSE	NA		
R1 (ohms/ph)	R2 (ohms/ph)	X1 (ohms/ph)	X2 (ohms/ph)	Xm (ohms/ph)	VIBRATION (in/sec)	FLOAT		
0.065	0.047	0.412	0.473	11.447	0.080	ODE		

* N O T E S *		INVERTER TORQUE: CONSTANT 2:1	
		INV. HP SPEED RANGE: NONE	
		ENCODER: NONE	
		BRAKE: NONE	
		FT-LB: NA	
		VOLTAGE: NONE	
		HZ: NONE	
		NONE PPR	

DATE:	2/1/2018	UL: Y:(LEESON UL REC)
-------	----------	-----------------------



Motor Load Data						
Load	0%	25%	50%	75%	100%	LR
Current (Amps)	24.0	29.0	40.0	54.0	70.0	435
Torque (ft-lb)	0.00	44.0	88.0	133	177	335
RPM	1800	1795	1790	1785	1780	0
Efficiency (%)		92.4	95.0	95.0	95.0	
P.F. (%)	4.0	52.0	73.5	81.5	85.0	31.0

Motor Speed Data						Information Block																					
LR	Pull-Up	BD	Rated	Idle		HP	Sync. RPM	Frame	Enclosure	Construction	Voltagge	Frequency	Design	LR Code letter	Service Factor	Temp Rise @ FL	Duty	Ambient	Elevation	Rotor/Shaft wk ²	Ref Wdg	Sound Pressure @ 1M	VFD Rating	Outline Dwg	Conn. Diag	Additional Specifications:	
0	900	1715	1780	1800		60.0	1800	364	TEFC	TFS	460	60	A	G	1.15	80	CONT	40	1,000	15.2	NONE	65	CONSTANT 2:1	B-SS508590LE-1350	A-EE7300-1E		
Current (Amps)	435	420	300	70.0	24.0																						
Torque (ft-lb)	335	300	465	177	0.00																						

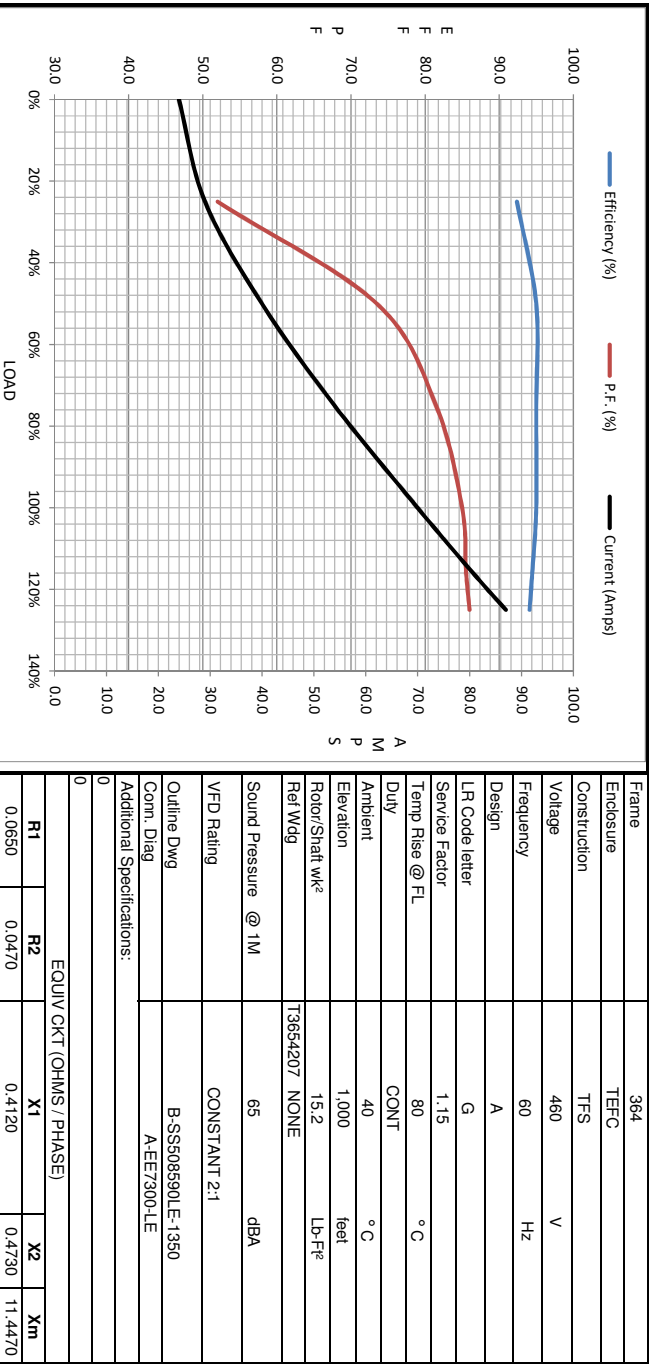

R1	R2	X1	X2	Xm
0.0650	0.0470	0.4120	0.4730	11.4470

EQUIV CKT (OHMS / PHASE)

